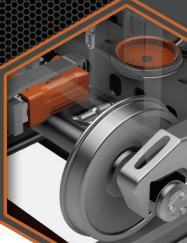
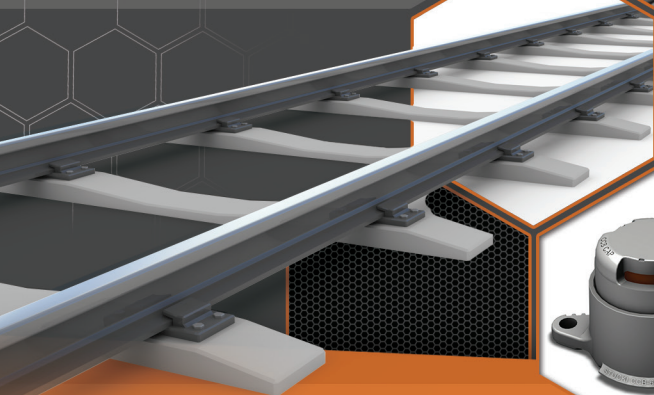


# PRODUCT GUIDE

**A.STUCKI**  
.....COMPANY




360 Wright Brothers Dr  
Pittsburgh, PA 15108

(412) 424-0560  
sales@stucki.com

WWW.STUCKI.COM

rev 09



**1.** This pocket guide provides recommended procedures for the inspection of products manufactured and reconditioned by the A. Stucki Company, including truck side bearings, body side bearings, friction wedges, column guide wear plates, springs, hydraulic stabilizers, hand brakes, brake beams, center bowl and brake beam liners, couplers, yokes, coupler mounting brackets, draft gears, and grating.

This guide is intended primarily for product identification, inspection, and maintenance guidance and does not cover initial product installation procedures. To obtain the latest news and information on all of Stucki's products, including drawings and installation instructions, please visit our website at [www.stucki.com](http://www.stucki.com).

## TABLE OF CONTENTS

<b>1. SCOPE</b>	
<b>2. TRUCK AND BODY SIDE BEARINGS</b> .....	<b>4</b>
Extended Travel CCSB .....	4
RetroXT Tank Car CCSB Upgrade .....	7
RetroXT CCSB Element Kit Upgrade .....	13
Standard Travel CCSB .....	14
Roller Side Bearings .....	23
Plate and Wedge .....	25
Yard and Shop Inspection .....	26
Free Height Measurement .....	34
Shelf Life Criteria and Date Codes .....	35
Vertical Setup Height Inspection .....	38
Vertical Setup Height Correct Repairs .....	45
Vertical Setup Height and Wear Indicators ....	49
Side Bearing Cross Reference .....	50
<b>3. SNUBBING SYSTEMS</b> .....	<b>52</b>
General Requirements .....	52
Product Cross Reference Table .....	54
S-2-A .....	58
S-2-B and S-2-C .....	55, 58, 62
S-2-HD .....	56, 59, 62
Ride Control® .....	55, 60
Super Service Ride Control® .....	56, 60
Super Service Ride Master® .....	57, 61
Yard Inspection .....	64
Shop Inspection .....	65
Wear Indicator .....	67
Control and Load Springs .....	68
Control Coils Table .....	69
Load Coils Table .....	70
Yard Inspection .....	71
Shop Inspection .....	71

## TABLE OF CONTENTS

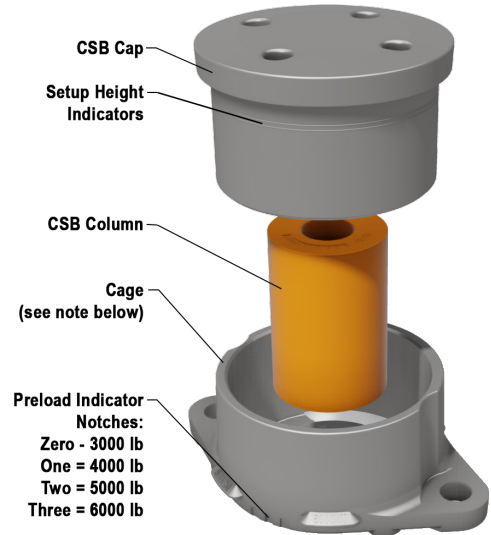
<b>4. HYDRAULIC STABILIZERS</b> .....	<b>72</b>
HydraShox™ Platinum .....	73
HydraShox™ Gold .....	74
Yard and Shop Inspection .....	75
<b>5. GRATING</b> .....	<b>79</b>
Grating .....	80
Product Reference Table .....	81
Accessories .....	82
<b>6. BRAKE SYSTEMS</b> .....	<b>83</b>
Brake Beams	
Product Reference Table .....	83
Inspection .....	84
Reversible Brake Beam Procedure .....	85
Replaceable Brake Head Procedure .....	87
RollGuard™ Hand Brake .....	88
Brake System Accessories .....	90
Brake Beam Centering Wear Liner .....	91
<b>7. DRAFT SYSTEMS</b> .....	<b>92</b>
Product Reference Table .....	93
PowRGuard™ Inspection Criteria .....	94
<b>8. REPAIR AND RECONDITIONING</b> .....	<b>95</b>
American Industries .....	96
American Industries Midwest .....	97
Independent Draft Gear .....	98
<b>9. BEARING ADAPTERS</b> .....	<b>102</b>
<b>10. PINS</b> .....	<b>104</b>

## 2. TRUCK AND BODY SIDE BEARINGS



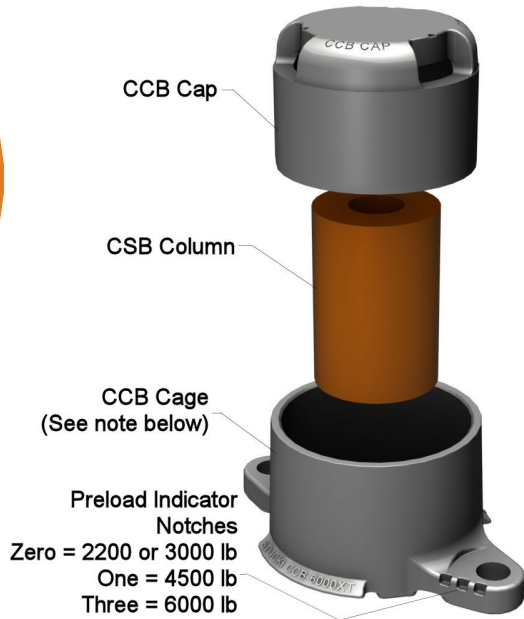
**FIG. 2.1 SHEAR SIDE BEARING (SSB®)**

Replacement cages are ordered by specifying preload, i.e. 6000XT Cage, where 6000 = preload, XT for extended travel.



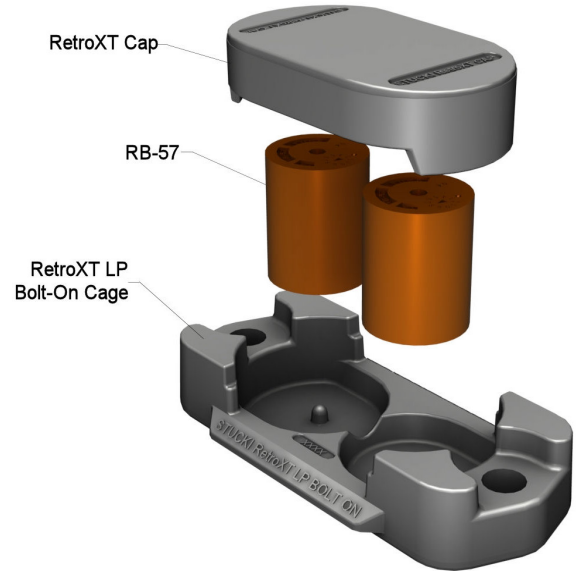
**FIG. 2.2 COLUMN SIDE BEARING (CSB®)**

Replacement cages are ordered by specifying preload, i.e. 6000XT Cage, where 6000 = preload, XT for extended travel.

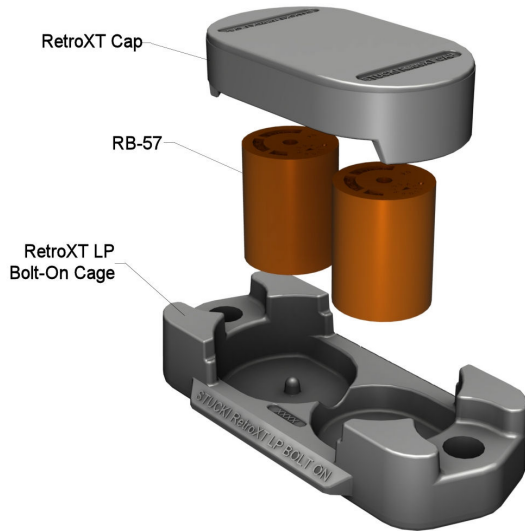


**FIG. 2.3 COMPACT COLUMN SIDE BEARING**

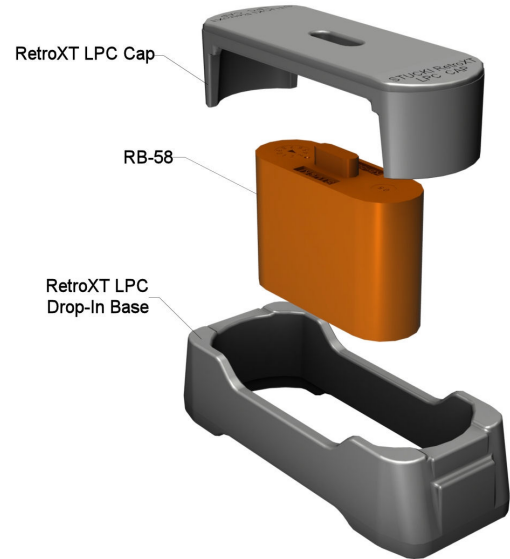
Replacement cages are ordered by specifying preload, i.e. CCB6000XT Cage, where 6000 = preload, XT for extended travel. Also available in 2200lb & 3000lb preload. The 2200lb & 3000lb models are not for interchange service.



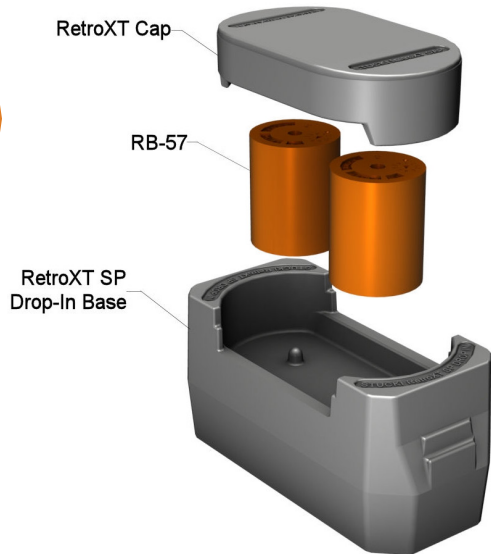
**FIG. 2.4 RETROXT LP BOLT-ON, 4500LB. PRELOAD**



**FIG. 2.5 RETROXT LP DROP-IN, 4500LB. PRELOAD**  
For monocast or welded bolster pocket, approximately  
4-1/4" x 9-1/4", low profile design.

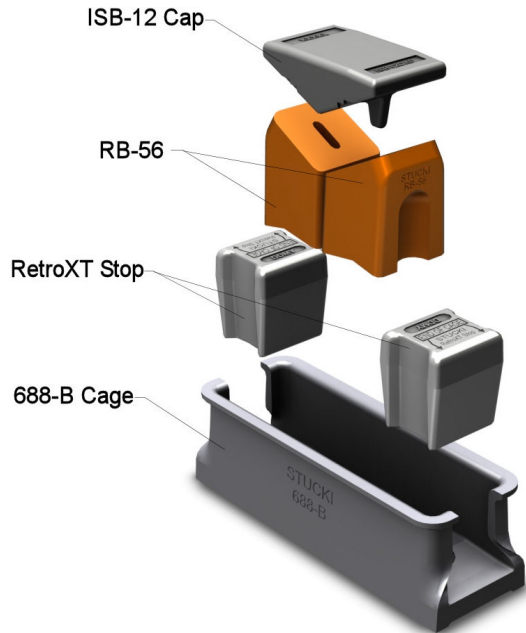


**FIG. 2.6 RETROXT LPC DROP-IN, 4500LB. PRELOAD**  
For monocast or welded bolster pocket, approximately  
3-1/2" x 8-1/4", low profile design.



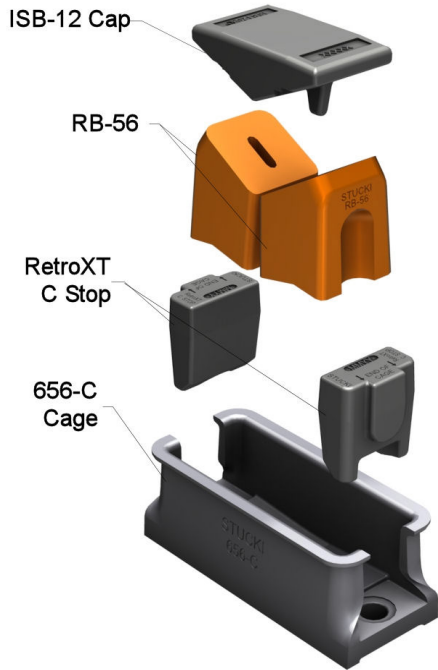
**FIG. 2.7 RETROXT SP DROP-IN, 4500LB.**

For monocast or welded bolster pocket, approximately 4-1/4" x 9-1/4", standard profile design.



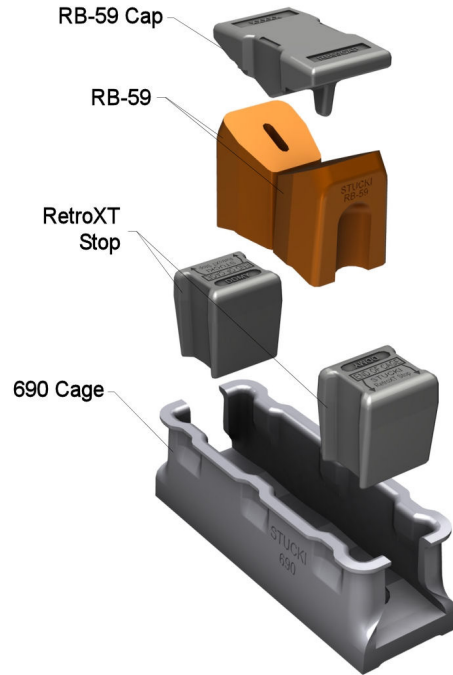
**FIG. 2.8 RETROXT 5400B, 5400LB. PRELOAD**

This is an extended travel upgrade for the 688-BR, the ISB-9DR, the ISB-12 and the 688-B. This drop-in kit is for application to existing cages and does not include a new cage.



**FIG. 2.9 RETROXT 5400C, 5400LB. PRELOAD**

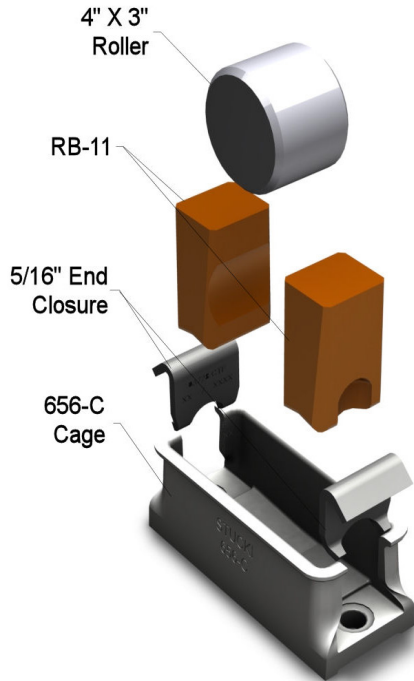
This is an extended travel upgrade for the 656-CR, the 656-CRH and the 656-C. This drop-in kit is for application to existing cages and does not include a new cage.



**FIG. 2.10 RETROXT 4500, 4500LB. PRELOAD**

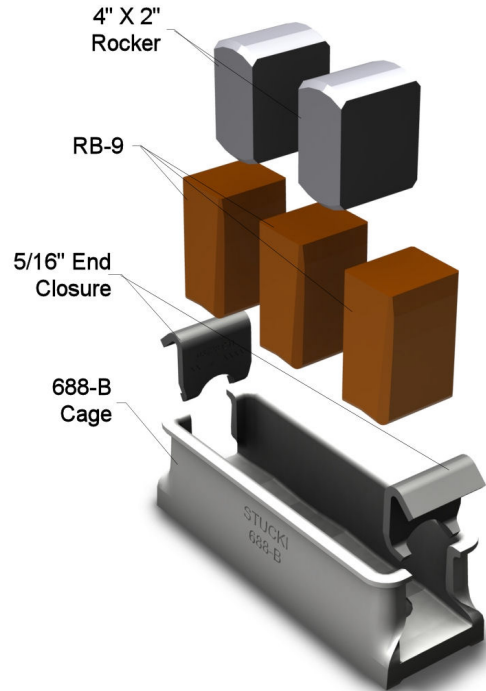
This is an extended travel upgrade for the 690-RL. This drop-in kit is for application to existing cages and does not include a new cage.





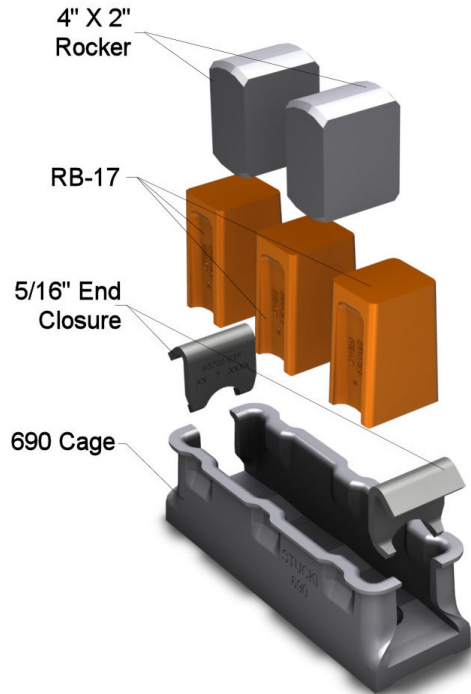
**FIG. 2.11 656-CR, 6000LB. PRELOAD**

The 656-C cage can accept the RetroXT 5400C upgrade kit to convert to extended travel. Model 656-CRL uses RB-14s with a preload of 3500lb.



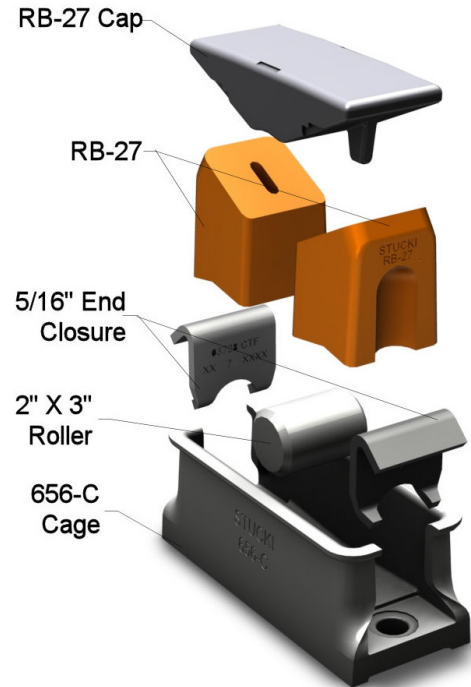
**FIG. 2.12 688-BR, 6000LB. PRELOAD**

This 688-B cage can accept the RetroXT 5400B upgrade kit to convert to extended travel.



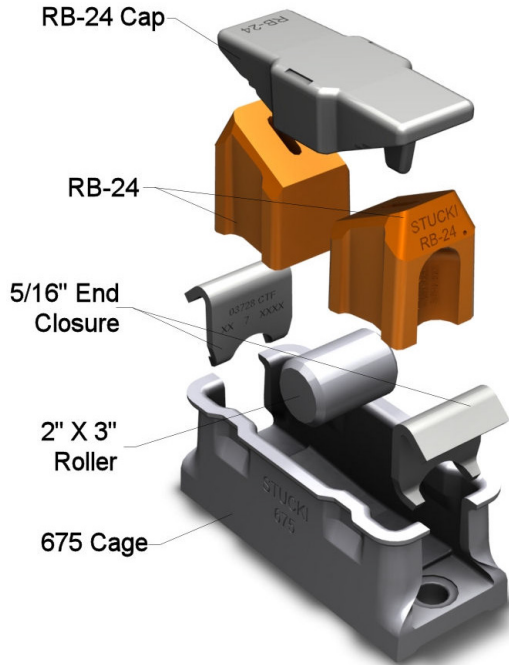
**FIG. 2.13 690-RL, 3600LB. PRELOAD**

The 690 cage can accept the RetroXT 4500 upgrade kit to convert to extended travel.



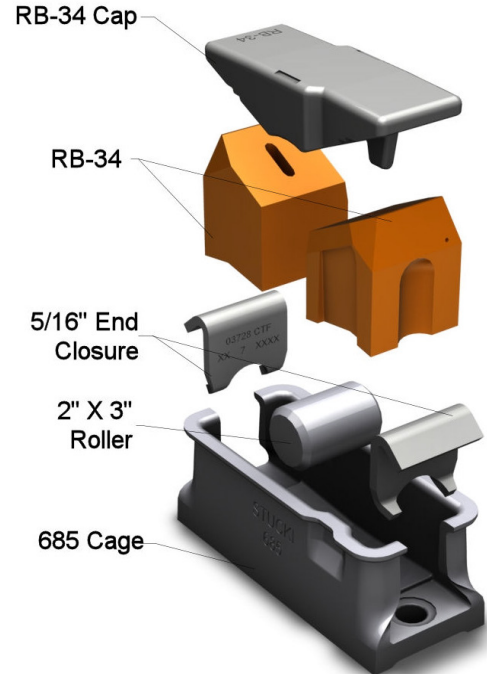
**FIG. 2.14 656-CRH, 5400LB. PRELOAD**

This 656-C cage can accept the RetroXT 5400C upgrade kit to convert to extended travel.

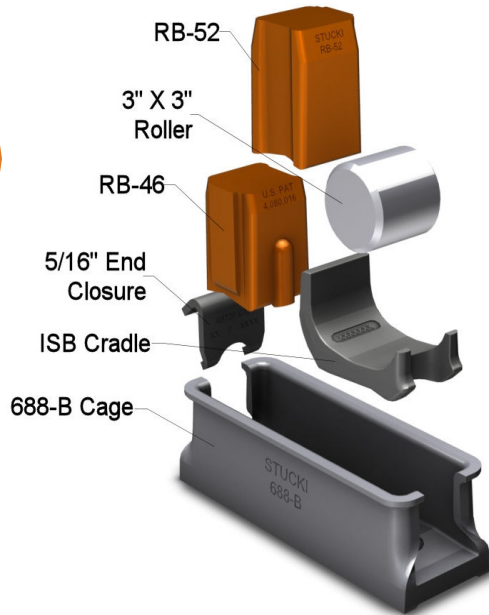


**FIG. 2.15 675-RL, 3000LB. PRELOAD**

Model 675-RXL uses RB-35s with a preload of 2200lb.

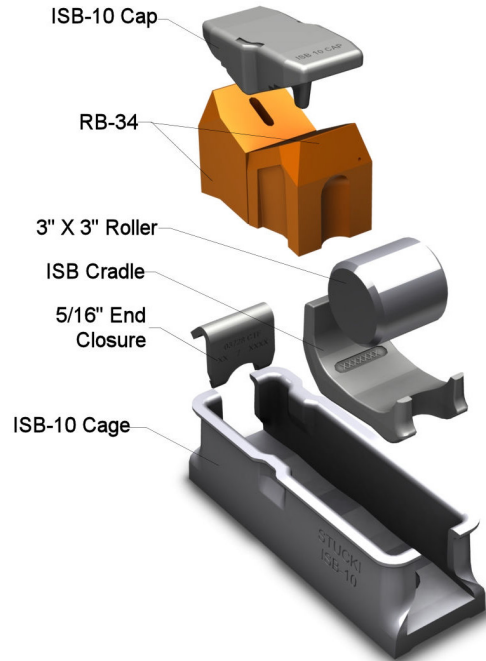


**FIG. 2.16 685-RM, 4500LB. PRELOAD**

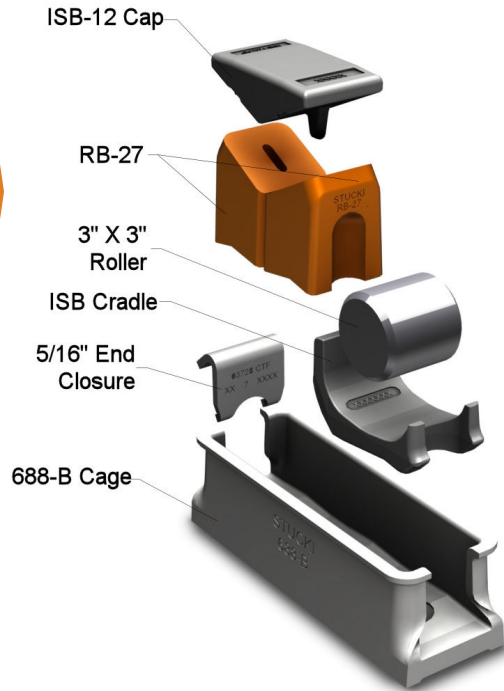


**FIG. 2.17 ISB-9DR, 4500LB. PRELOAD**

The RB 36 / 46 combination is no longer available and should be replaced with RB 46 / 52. In addition, the 688-B cage can accept the RetroXT 5400B upgrade kit to convert to extended travel.

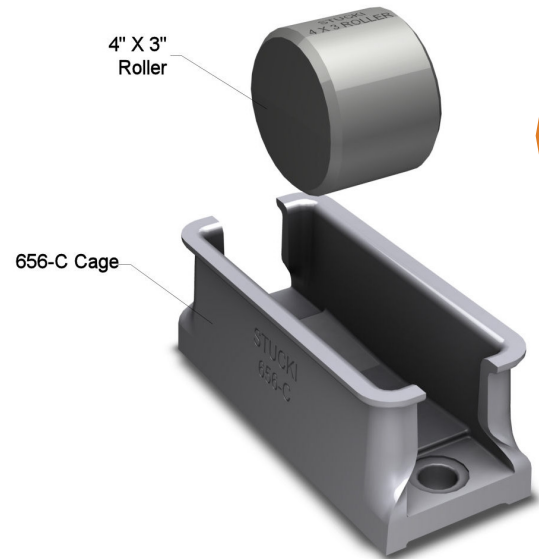


**FIG. 2.19 ISB-10, 4500LB. PRELOAD**



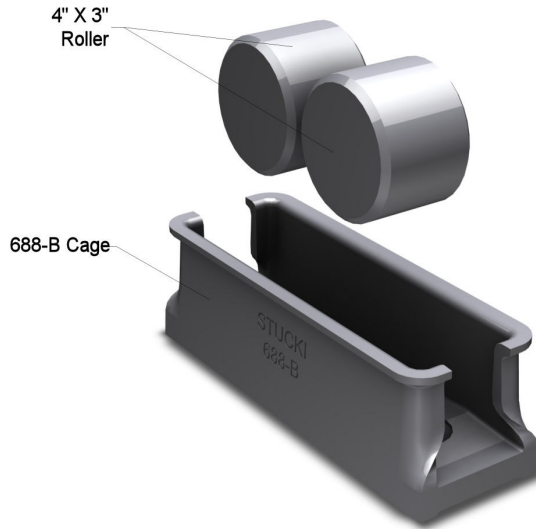
**FIG. 2.20 ISB-12, 5400LB. PRELOAD**

This 688-B cage can accept the RetroXT 5400B upgrade kit to convert to extended travel. Model ISB-12L uses RB24s with a preload of 3000lb.



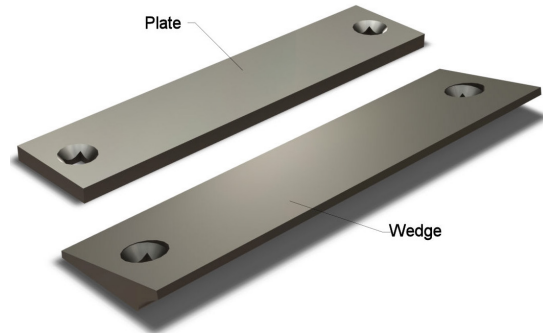
**FIG. 2.21 656-C**

The 656-C cage can accept the RetroXT 5400C upgrade kit to convert to extended travel.



**FIG. 2.22 688-B**

This 688-B cage can accept the RetroXT 5400B upgrade kit to convert to extended travel.



**FIG. 2.23 BODY SIDE BEARINGS (PLATE & WEDGE)**

Various length and hole center combinations are available for models 438P, 458P, 558P, 4W and 5W. Contact A. Stucki Company for specific applications.

## YARD AND SHOP INSPECTION

Physically identify the side bearing model from the illustrations in Section 2 Truck and Body Side Bearings. Be sure all components for that model are present and in the correct orientation. Missing or damaged components should be replaced in kind.

If the car is shopped, chock the wheels, safely lift the car, and follow standard safe operating procedures.

## CAGE

Inspect cages for cracks, flaws, or unusual deformation. The cage must be securely fastened to the truck bolster. If shopped, tighten or replace loose fasteners according to A. Stucki Company's installation instructions for respective side bearings. Broken or cracked cages must be replaced.

**BODY SIDE BEARING**

Plates or wedges must be securely tightened (torque bolts to minimum of 300 ft-lb) and tack welded.

Fastener heads must be recessed below the bearing surface of the wear plate or wedge.

All bearing surfaces should be flat or convex (1/16" maximum).

If shopped, replace plates or wedges if surface variations between fastener holes are greater than 1/8" or greater than 1/16" over any 4" span. The wear surface of the plate or wedge must be parallel to the side bearing mounting surface of the truck bolster to within 1/16" across the width and 1/8" along the length. Heavy rust or surface projections may be removed by grinding.

Please refer to AAR Specification S-235 and Rule 61 in the AAR Field Manual for additional requirements.

**ROLLER**

For shop inspection, rollers should be replaced if they have a diameter less than that shown in the table below:

TABLE 2.1

ROLLER SIZE (IN)	MINIMUM DIAMETER (IN)
2 X 3	1-15/16
3 X 3	2-7/8
4 X 3	3-13/16

The roller should also be replaced if the edges are deformed to the point that the roller will not roll freely in the cage or the chamfer cannot be seen.

**END CLOSURE**

End closures must be in place and not broken. ISB models have only one end closure.

**RESILIENT ELEMENT**

Resilient elements should be checked for any excessive deformation. If signs of severe cracking, bulging or deformation exist, replace the block in kind.



Refer to Rule 62 in the AAR Field Manual for additional requirements. Note that the 688-BR and 690-RL cars should not be shopped for repairs for a single block having a missing top portion. Replace the defective block when the car is next shopped for required maintenance or other repairs. Bad-order the car only if two or more block tops are missing.

Shop inspection additionally requires checking for cracks and gouges. Some elements (RB-46, RB-56, RB-57, RB-58, RB-59 & CSB® Column) are composed of a single material, while others consist of two materials. Most dual material designs will exhibit slight separation at the horizontal interface of those two materials. Blocks showing superficial horizontal separation do not need replaced. As a rule, if the interface can be manually opened to reveal 50% or more of the interface surface, the block should be replaced.

Vertical cracks are acceptable unless there are more than two cracks, greater than 1/2" in length, located in the bottom portion of the block. Cracked or missing top edges of wedge-shaped blocks do not affect its performance and is not cause for renewal.

### **ROCKER**

Rockers may not always be seated on the bottom of the cage, and clearance should not be used as a setup height criterion. While in service, vertical movement may occur. This has no effect on the performance of the side bearing. Rockers contact the body side bearing as the car rocks or leans. Light wear of the upper and lower surfaces of the rockers is normal and should be replaced if the diameter is less than 3-7/8".

## FREE HEIGHT MEASUREMENT

The suitability of the resilient blocks for continued service can be determined by their free height measurement. Allow the blocks to relax at least one hour at room temperature after removal from the car. Then measure the height from the base to the highest point on the block (see Table 2.2).

TABLE 2.2

BLOCK TYPE	MINIMUM ALLOWABLE FREE HEIGHT
RB-9	4-3/16"
RB-11	4-5/16"
RB-14	4-1/4"
RB-17	4-3/16"
RB-24	3-5/8"
RB-27	3-13/16"
RB-34	3-3/4"
RB-35	3-17/32"
RB-36	4-7/16"
RB-42	3-7/16"
RB-46	4-3/16"
RB-52	4-7/16"
SSB <sup>®</sup> Cap Assembly	4-15/16"
CSB <sup>®</sup> Column	4-5/16"
RB-56	3-11/16"
RB-57	2-5/16"
RB-58	2-5/16"
RB-59	3-11/16"

## SHELF LIFE CRITERIA AND DATE CODES

A. Stucki Company recommends a maximum shelf life of 5 years for all of our elastomer components, which includes RB Blocks, CSB® Columns, SSB® Elements, and RFE Pads. The shelf life is defined as the time from the manufacturing date of the parts until they are installed on the car. Please refer to Figures 2.24 and 2.25 for the proper methods of determining the manufacturing date.

### WARNING

Always use A. Stucki OEM replacement blocks for all Stucki side bearing designs. Failure to do so voids all Stucki support and warranty for Stucki cages and any resulting static or dynamic performance behavior. All side bearing warranties are null and void when using nonOEM replacement blocks as freight car, truck performance, and/or wheel wear issues could arise.

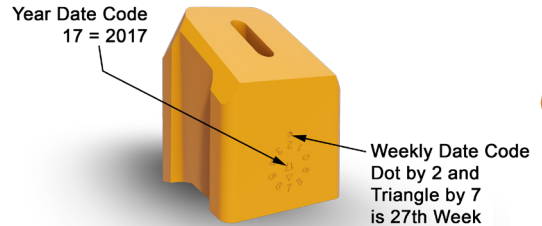


FIGURE 2.24

Date Code:  
41/16 is week 41  
of year 2016

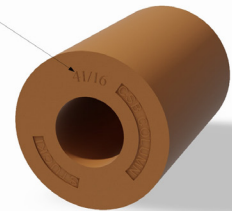


FIGURE 2.25

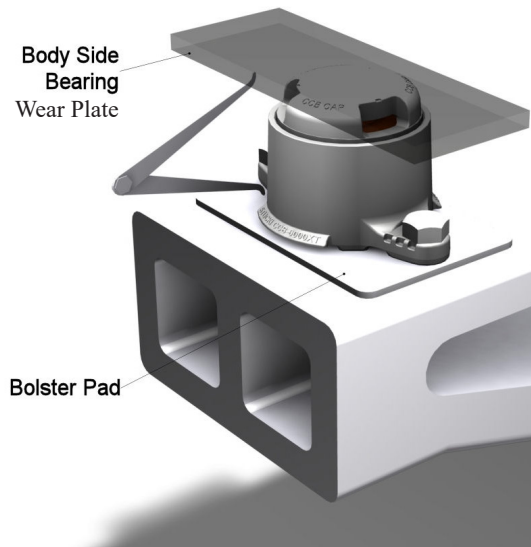
## VERTICAL SETUP HEIGHT INSPECTION

Rule 62 of the AAR Field Manual contains detailed condemning limits for the inspection of side bearing setup heights in the shop, on a repair track, or at any time. Tables 2.3 and 2.4 provide the specific location in Rule 62 to find these criteria based on the particular side bearing application.

TABLE 2.3 VERTICAL SETUP HEIGHT (ANY TIME)

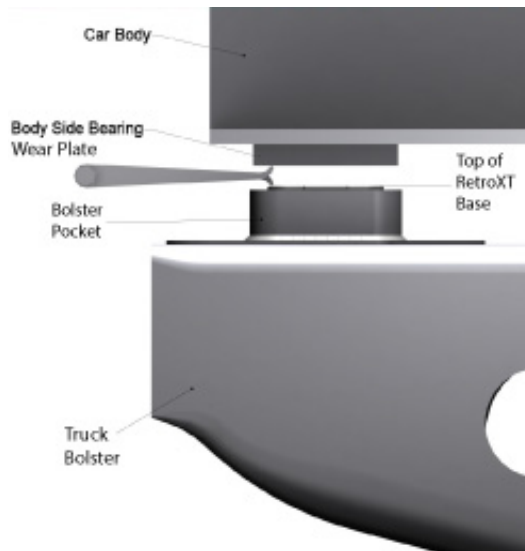
SIDE BEARING APPLICATION	RULE 62 SETUP HEIGHT CONDEMNING LIMIT	STUCKI MEASUREMENT TECHNIQUE
4-Axle Cars and End Trucks of Articulated Cars	Section A.1.h.(1)	Stucki Fig. 2.26 (Pg 42)
Articulated Positions of Articulated Cars	Section A.1.h.(2)	Stucki Fig. 2.26 (Page 42)
Cars with Solid Block Style Side Bearing Pockets (RetroXT LP, LPC and SP)	Section A.1.h.(3)	Stucki Fig. 2.27 (Pg 43) and Stucki Fig. 2.28 (Pg 44)

If applying new, 12" graphite lube disks or non-metallic bowl liner when constant contact side bearing measurements are being made, add an additional .1/16" to the nominal height for any single side bearing measurement and 1/8" to any nominal sum-of-the-pair measurements.



**FIG. 2.26 HOW TO MEASURE VERTICAL SETUP HEIGHT**

Place measuring tool as close to SB center as possible.



**FIG. 2.27 VERTICAL SETUP HEIGHT FOR RETROXT LP DROP-IN, BOLT-ON AND SP DROP-IN**

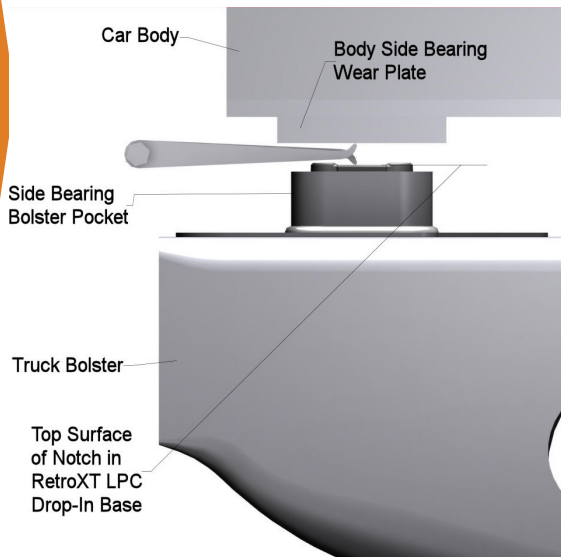


FIG. 2.28 VERTICAL SETUP HEIGHT FOR RETROXT LPC

TABLE 2.4 VERTICAL SETUP HEIGHT (SHOP OR REPAIR TRACK)

SIDE BEARING APPLICATION	RULE 62 SETUP HEIGHT CONDEMNING LIMIT	STUCKI MEASUREMENT TECHNIQUE
4-Axle Cars and End Trucks of Articulated Cars	Section A.2.a.(1)	Stucki Figure 2.26 (Page 42)
Articulated Positions of Articulated Cars	Section A.2.a.(2)	Stucki Figure 2.26 (Page 42)
Cars with Solid Block Style Side Bearing Pockets (RetroXT LP, LPC and SP)	Section A.2.a.(3)	Stucki Figure 2.27 (Page 43) and Stucki Figure 2.28 (Page 44)

If applying new, 12" graphite lube disks or non-metallic bowl liner when constant contact side bearing measurements are being made, add an additional 1/16" to the nominal height for any single side bearing measurement and 1/8" to any nominal sum-of-the-pair measurements.

All side bearing setup height measurements should be taken . . .

- On straight and level track
- As close to the center of the side bearing as possible

Be alert to the possibility of encountering shims under side bearing cages. This practice should be avoided, but when present, measurement must reference to the top of these shims, rather than the mounting surface of the bolster.

If the appropriate Rule 62 setup height condemning limits are exceeded and the car is empty, it must be shopped and the car body side bearing shims adjusted to obtain the specified setup height. Refer to Vertical Setup Height Correct Repairs on Page 47.

## VERTICAL SETUP HEIGHT CORRECT REPAIRS

If inspection measurements reveal that the side bearing setup height violates the Rule 62 condemning limits, then body side bearing shim adjustments are required to correct the out-of-specification condition.

To increase the setup height, shims must be removed. Likewise, to reduce the setup height, shims must be added to the car body side bearing. Do not place shims under side bearing cages to adjust setup heights, unless shimming beneath cages is the only option.

When adjusting side bearing setup height in the shop, the vertical distance between the body side bearing wear plate or wedge and the truck bolster surface to which the side bearing is mounted must be  $5\text{-}1/16'' \pm 1/16''$  unless otherwise stenciled on the car body (Figure 2.29).

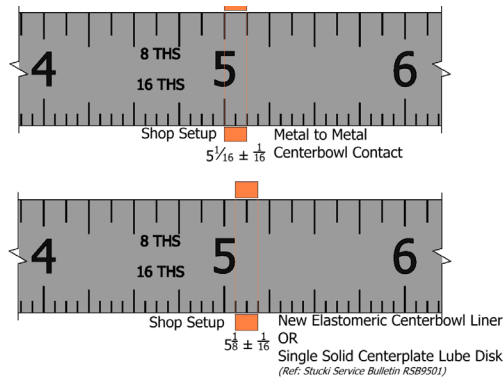


FIG. 2.29

For the RetroXT LP and SP side bearings, the vertical space between the top of the cage and the underside, or wearing surface of the body side bearing wear plate or wedge must be  $11/16'' \pm 1/16''$ . For the RetroXT LPC side bearing, the vertical space between the top of the notch and the underside, or wearing surface of the body side bearing wear plate or wedge must be  $11/16'' \pm 1/16''$  (Figure 2.30).

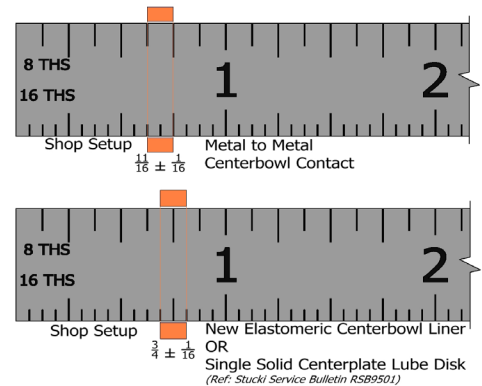


FIG. 2.30



These measurements assume that the car is empty, positioned on reasonably level track, and has positive centerplate contact. Tops of metal rockers or rollers should not be used as reference points to measure setup height for constant contact side bearings.

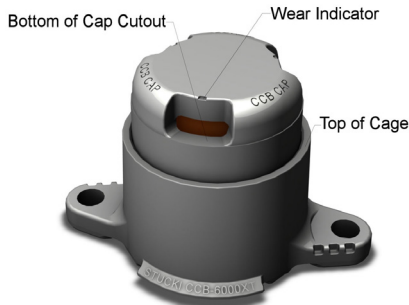
If the car is equipped with any type of new 12" graphite lube discs or elastomeric center bowl liner, it must be in place when measuring for setup height adjustment. In addition, side bearing setup heights should be adjusted to  $3/4" \pm 1/16"$  for all RetroXT LP, LPC or SP side bearings and  $5-1/8" \pm 1/16"$  for all other side bearing products.

Never relubricate a side bearing in service, unless the metal caps or body side bearings are being replaced. In this case, apply a 1-1/2" diameter dab of lithium based grease to the center of the side bearing cap. This allows the body side bearing wear plate surface to polish, resulting in smooth consistent turning of the truck.

## VERTICAL SETUP HEIGHT AND WEAR INDICATORS

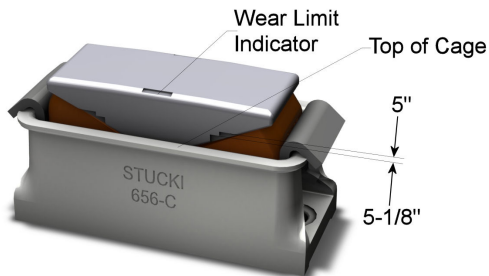
Figures 2.31, 2.32, 2.33, 2.34 and 2.35 highlight reference indicators which can be used for quick visual inspection of wear or proper setup height. Please note, the setup height indicators are for reference only and should not be used when installing new side bearings or making side bearing setup height adjustments on a repair track or in the shop.

Cap wear limit indicators for all CCB and metal capped/rolled steel cage designs are shown in Figures 2.31 and 2.32. Caps should be replaced when any wear indicator limit is worn off. Cap wear limits for all LP, SP, LPC, CSB® and SSB® designs are reached when applying a straight edge across the cap and reaching both outside edges of the cap at the same time as shown in Figures 2.33 and 2.35. Replace the cap when this condition is met.



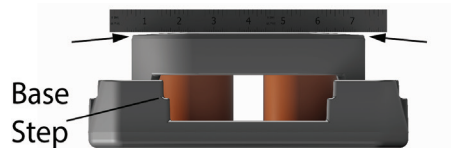
**FIG. 2.31 SETUP HEIGHT INDICATOR FOR COMPACT COLUMN SIDE BEARING**

Setup is at  $5\text{-}1/16''$  when bottom cap cutout is aligned with top of cage. Side bearing is shown at free height.



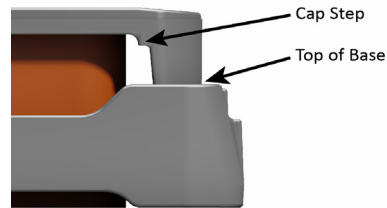
**FIG. 2.32 SETUP HEIGHT INDICATOR FOR METAL CAPPED, ROLLED-STEEL CAGE DESIGNS**

If the top of cage is aligned at lateral center of top notch, setup height is at  $5\text{-}1/16''$ .



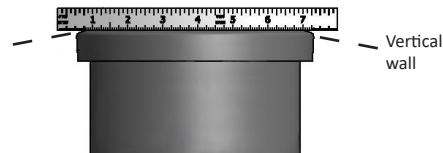
**FIG. 2.33 WEAR LIMIT INDICATOR FOR RETROXT LP, LPC, SP AND SSB<sup>®</sup> SIDE BEARINGS**

Caps are condemnable when both vertical walls are contacted using a straight edge placed across the top of the cap.



**FIG. 2.34 SETUP HEIGHT INDICATOR FOR RETROXT LPC SIDE BEARINGS**

Setup is at  $11/16''$  when the bottom of cap is aligned with the base step of the LP and SP models or when cap step is aligned with top of base for the LPC model. All side bearings are shown at free height.



**FIG. 2.35 CSB<sup>®</sup> AND SSB<sup>®</sup> CAP**

TABLE 2.5 SIDE BEARING CROSS REFERENCE

STUCKI SIDE BEARING				MINER SIDE BEARING				STANDARD CAR TRUCK SIDE BEARING				
MODEL	HOUSING	TOP CAP	ELEMENT	MODEL	HOUSING	TOP CAP	PAD	MODEL	ASSEMBLY	HOUSING	TOP CAP	ELEMENT
CCB-3000XT	CCB-3000XT*	CCB Wear Cap	CSB Column	TCC-III-30 LT	40141	40136	T-0305	SBX-30	6475	6473	6472	6474
CCB-4500XT	CCB-4500XT	CCB Wear Cap	CSB Column	TCC-III-45 LT	40142	40136	T-0300	SBX-45	6480	6478	6472	6479
CCB-6000XT	CCB-6000XT	CCB Wear Cap	CSB Column	TCC-III-60 LT	40143	40136	T-0306	SBX-60	6485	6483	6472	6484
CCB-8000XT	CCB-8000XT	CCB Wear Cap	CSB Column	TCC-III-80 LT	40144	40136	T-0307	SBX-80	6490	6488	6472	6489
<b>MINER SIDE BEARING</b>												
MODEL	HOUSING	TOP CAP	ELEMENT	MODEL	HOUSING	TOP CAP	PAD	NO EQUIVALENT				
CCB-3000XT	3000XT	CSB Wear Cap	CSB Column	TCC-IV30 LT	40141	40482	T-0432					
CCB-4000XT	4000XT	CSB Wear Cap	CSB Column	TCC-IV45 LT	40142	40482	T-0430					
CCB-5000XT	5000XT	CSB Wear Cap	CSB Column	TCC-IV60 LT	40143	40482	T-0431					
CCB-8000XT	CCB-8000XT	CSB Wear Cap	CSB Column	TCC-IV80 LT	40144	40482	T-0434	NO EQUIVALENT				
<b>STUCKI SIDE BEARING</b>												
MODEL	HOUSING	TOP CAP	ELEMENT	NO EQUIVALENT								
SSB-4000XT	4000XT	SSB Wear Cap	SSB Wear Cap									
SSB-5000XT	5000XT	SSB Wear Cap	SSB Wear Cap									
SSB-6000XT	6000XT	SSB Wear Cap	SSB Wear Cap									

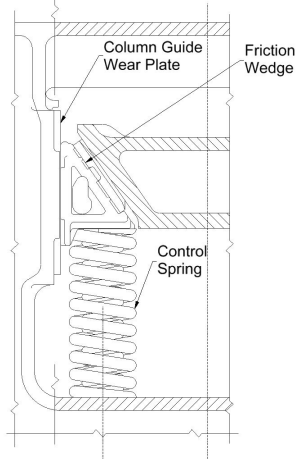
All Stucki extended travel side bearings can be applied as replacement to those molds listed in the center and right hand columns. All side bearing parts must be replaced by complete unit, cage, cap and column. Both side bearings on each truck should match designs, and preferably all four locations of car for proper balance and ride quality.

\* Note that CCB-3000XT is not for interchange service.

### 3. SNUBBING SYSTEMS

#### GENERAL REQUIREMENTS

Snubbing Systems are composed of three main product groups, including friction elements, springs and column guide wear plates. These are responsible for stabilization of the truck. System wear of the snubbing column can be measured by checking friction wedge rise with a mustache gage per AAR Field Manual Rule 46 and AAR Office Manual Rule 88.



The following illustrations identify each friction element and its components. It is important that all components shown for a specific wedge are present and in good condition. Missing or severely worn RFE pads should be replaced. Pads manufactured by A. Stucki Company are identified by their orange color. Table 3.1 cross references product.

TABLE 3-1. FRICTION WEDGE CROSS REFERENCE TABLE

MANUFACTURER	TRUCK TYPE	Stucki Friction Wedge Equivalent		
		RESILIENT PAD	CONVENTIONAL WEDGE	SPLIT WEDGE
Barber 609-D	70T & 100T Barber S-2-A	RFE-16 *	ASC-609D	
Barber 888R, 888N, 787C & 925SW	70T & 100T Barber S-2-B, C	RFE-16	ASC-787	ASC-925SW, 925L, 925R, 5824 (Thick) & 5286 (Thin)
Barber 876	100T S-2-D	RFE-51	ASC-876	
Barber 834-C & 915SW	100T S-2-HD Heavy Duty	RFE-41	ASC-834CB	ASC-915SW, 915L, 915R & 5821
ASF 17803 & 17849	70T, 100T & 125T Ride Control	RFE-18	ASC-17803	
ASF 17823	100T RideMaster		ASC-17823	
ASF 17815 & 17852	100T Super Service Ride Control	RFE-26	ASC-17815	
ASF 17882	100T Super Service RideMaster	RFE-53	ASC-17882	
ASF 17882	100T Motion Control	RFE-53	ASC-17882	

\* Requires use of Stucki RFE-16 D-5 wedge springs (or Barber B432/B433 combination) with 3/8" Stucki shim plate.

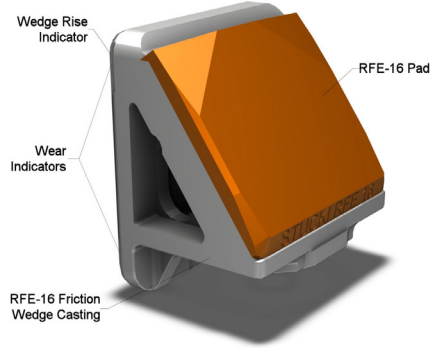


FIG. 3.1 RFE-16 FOR BARBER® S-2-B, C TRUCKS

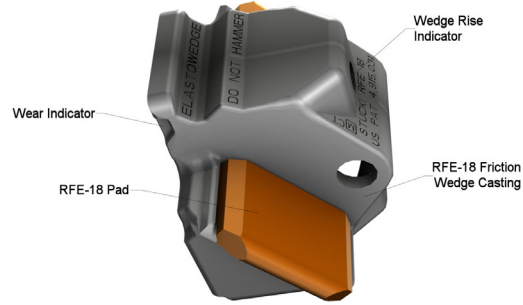
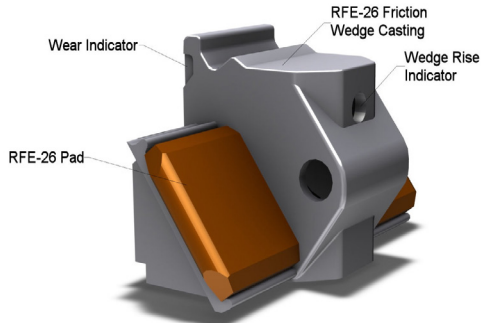
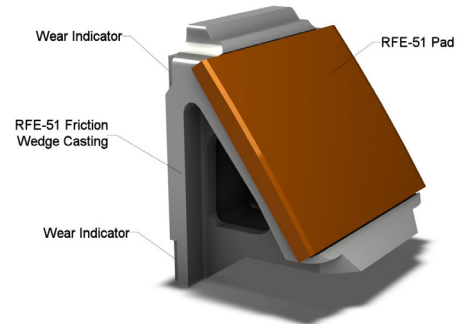


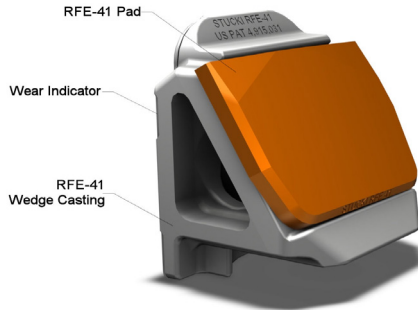
FIG. 3.2 RFE-18 FOR RIDE CONTROL® TRUCKS



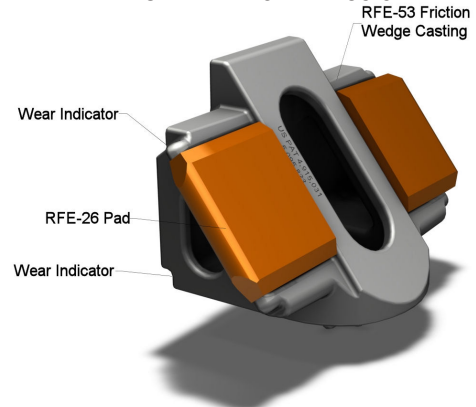
**FIG. 3.3 RFE-26 FOR SUPER SERVICE RIDE CONTROL™ TRUCKS**



**FIG. 3.5 RFE-51 FOR BARBER® S-2-D TRUCKS**



**FIG. 3.4 RFE-41 FOR BARBER® S-2-HD TRUCKS**



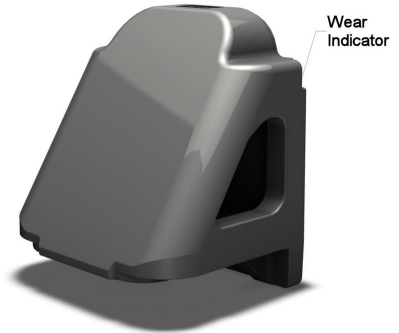
**FIG. 3.6 RFE-53 FOR SUPER SERVICE RIDE MASTER® TRUCKS**



**FIG. 3.7 ASC-609D FRICTION CASTING FOR BARBER® S-2-A TRUCKS**



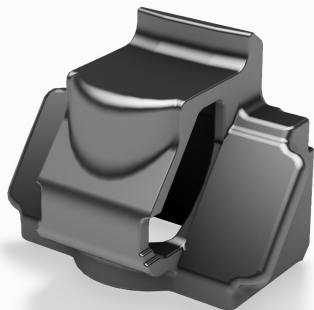
**FIG. 3.8 ASC-787C FRICTION CASTING FOR BARBER® S-2-B, C TRUCKS**



**FIG. 3.9 ASC-834CB FRICTION CASTING FOR BARBER® S-2-HD TRUCKS**



**FIG. 3.10 ASC-876 FRICTION CASTING FOR BARBER® S-2-D TRUCKS**



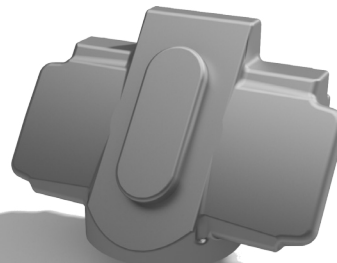
**FIG. 3.11 ASC-17803  
FOR RIDE CONTROL® TRUCKS**



**FIG. 3.13 ASC-17823 SPLIT WEDGE  
FOR RIDE MASTER® TRUCKS**

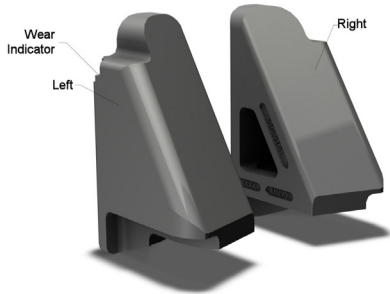


**FIG. 3.12 ASC-17815  
FOR SUPER SERVICE RIDE CONTROL® TRUCKS**

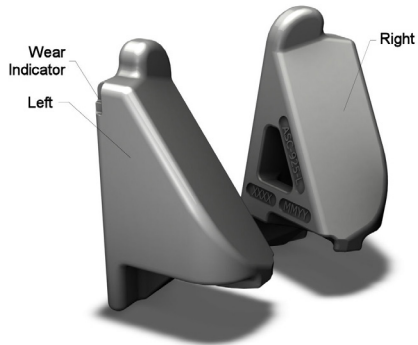


**FIG. 3.14 ASC-17882  
FOR SUPER SERVICE RIDE MASTER® OR MOTION CONTROL**

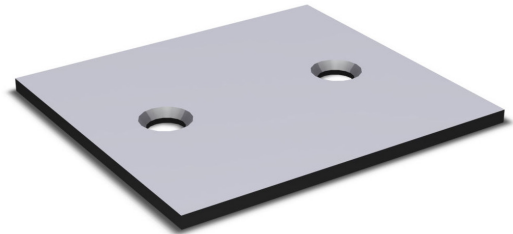




**FIG. 3.15 ASC-915 SPLIT WEDGE  
FOR BARBER® S-2-HD TRUCKS**  
ASC-5821 Wedge Inserts also available.



**FIG. 3.16 ASC-925 SPLIT WEDGE  
FOR BARBER® S-2-B, C TRUCKS**  
ASC-5824 (Thick) & ASC-5286 (Thin)  
Wedge Inserts also available.



**FIG. 3.17 COLUMN GUIDE WEAR PLATE  
ALL POPULAR SIZES**  
Contact A. Stucki Company for specific applications.

## YARD INSPECTION

Inspect wear indicators on the vertical face of the wedge. Replace wedges when the wear indicators are no longer visible. New wedges will have approximately 3/8" of wear indicator visible. A mustache gage can be used to check wedge rise for all wedge designs. Wedge rise limits for RFEs and split wedges are the same as for the conventional friction shoes they replace (see AAR Field Manual, Rule 46). For the RFEs 18 and 26, wedge rise is excessive when the hole on the front of the casting is entirely above the top plate of the bolster. The RFE-16 wedge rise limit indicator is the bottom of the face wear indicator itself.

Check top edge of resilient urethane pads for flush seating against the wedge and bolster pocket. Any pad cracks above the area of contact with the bolster pocket are acceptable and are not cause for renewal.

## SHOP INSPECTION

In addition to the previous yard inspection procedures, inspection in the repair shop should include the following procedures:

### COLUMN GUIDE WEAR PLATE

Check closely for cracks, loose or missing fasteners, or excessive wear, and replace as necessary. Refer to AAR Specification S-3003 and Field Manual Rule 48, Table 1. Column guide wear plates must be reasonably parallel, and spacing between plates must be in accordance with AAR requirements.

### RFE CASTING

Wedges having obvious cracks must be replaced.

### WEDGE

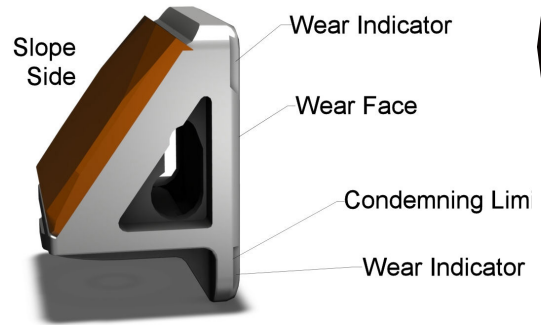
If wedge rise measurements indicate wedges are above condemnable heights, both complete wedges should be replaced. The exception is if resilient pad(s) are severely damaged, and casting has at least 3/16" face wear indicator remaining,

then it is acceptable to replace the pads only. Pry old pads from the casting with a screwdriver, and install new pads by aligning the post on the back of the pad with the hole in the sloped face of the casting. Strike the pad face with a mallet to seat it onto the casting.

**ELASTOMER PADS**

Patches of dark, flaky material on the faces of the pads are common, and produce no detrimental effects. This is not cause for renewal. Missing or severely worn RFE pads should be replaced.

In the case of the RFE-18, RFE-26 and RFE-53, if cracks emanating from the upper or lower corners of the pads have extended downward toward the center of the pad more than 3/4", then cracked pads should be replaced.



**FIG. 3.18 WEAR INDICATOR SIDE VIEW (MOST WEDGES)**

### CONTROL AND LOAD SPRINGS

Springs can be identified by the markings on the tapered ends or by physical identification using Tables 3.2 and 3.3. Broken wedge springs must be replaced. Free heights of springs should be checked.

TABLE 3.2 CONTROL COILS TABLE (INCHES)

PART NUMBER	BAR DIAMETER	OUTER DIAMETER	SOLID HEIGHT	FREE HEIGHT	SCRAP HEIGHT
B353	13/16	4 7/8	6 9/16	11 3/16	10 5/8
B354	17/32	3 1/8	6 9/16	11 1/2	10 15/16
B421	43/64	3 11/16	6 9/16	10 3/8	9 15/16
B422	13/32	2 3/16	6 1/16	9 3/4	9 5/16
B432	43/64	3 7/8	6 9/16	11 1/16	10 1/2
B433	7/16	2 13/32	6 15/16	11 3/8	10 13/16
3023	9/16	3 1/4	4 7/8	7 9/16	7.125
3024	3/8	2	4 7/8	7 1/4	7
3091	19/32	3 1/4	4 7/8	7 5/16	7
3092	3/8	1 15/16	4 7/8	7 3/16	7
5062	25/32	5	6 1/2	12 9/16	12
5063	17/32	3 5/16	6 1/2	12 11/16	12 1/8

TABLE 3-3 LOAD COILS TABLE (INCHES)

PART NUMBER	BAR DIAMETER	OUTER DIAMETER	SOLID HEIGHT	FREE HEIGHT	SCRAP HEIGHT
D2 Inner	11/16	2 15/16	6 5/8	8 1/4	7 15/16
D2 Outer	1 7/32	5 1/2	6 5/8	8 1/4	7 15/16
D3 Inner	21/32	3 1/4	6 9/16	9 1/16	8 5/8
D3 Outer	1 1/16	5 1/2	6 9/16	9 1/16	8 5/8
D4 Inner	5/8	3 3/8	6 9/16	9 5/8	9 1/16
D4 Outer	1	5 1/2	6 9/16	9 5/8	9 1/16
D5 Inner	5/8	3 3/8	6 9/16	10 5/16	9 5/8
D5 Outer	61/64	5 1/2	6 9/16	10 1/4	9 5/8
D6 Inner	21/32	3 7/16	6 9/16	9 15/16	9 5/16
D6A Inner	3/8	2	5 11/16	9	8 3/8
D7 Inner	5/8	3 1/2	6 9/16	10 3/4	10

### YARD INSPECTION

Any cracked, broken or missing springs should be replaced in kind. Any flattening of the spring coil top on **all** windings top to bottom, are signs of spring overload or bottoming. These should be checked for free height.

### SHOP INSPECTION

Using a straight edge held across the top of a free standing spring, compare the free height measurement of the spring to the minimum recommended scrap height in Tables 3.2 and 3.3. If the spring does not return to the scrap height, replace in kind.

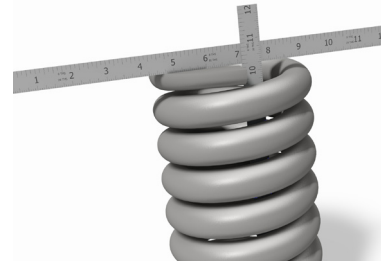
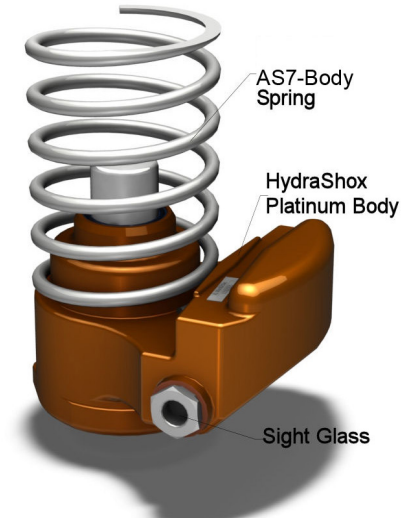


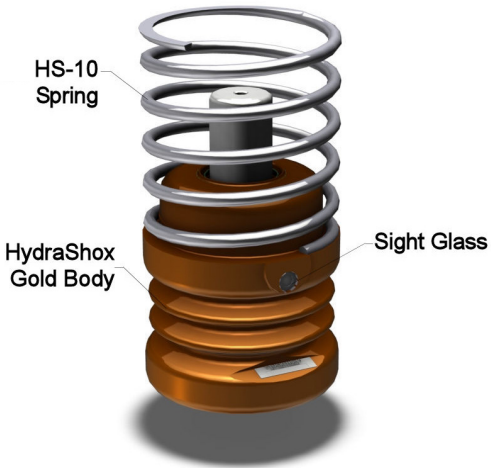
FIG. 3.19 SPRING MEASUREMENT

## 4. HYDRAULIC STABILIZERS

Stucki hydraulic stabilizers are the only hydraulic damping units guaranteed to meet AAR Specification M-965, AAR Field Manual Rule 50 and Rule 88 to ensure safe operation of the freight car while controlling resonant rocking of high-center-of-gravity cars with D5 or D4 springs. The Stucki HydraShox™ products utilize a high pressure seal which provides superior performance and life while preserving oil reserve levels. This fluid loss is compensated for by the reserve oil. The Stucki HS-7 and HS-10 incorporate a low pressure seal on the piston rod, which may pass slight amounts of oil under normal operating conditions.



**FIG. 4.1 HYDRASHOX™ PLATINUM**  
HS-7 available unpainted / reconditioned only.



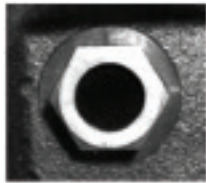
**FIG. 4.2 HYDRASHOX™ GOLD**

## YARD AND SHOP INSPECTION

Hydraulic stabilizers should be positioned vertically upright with the body spring properly seated between the stabilizer and the bolster. Units not properly positioned or seated on the side frame must be repositioned or seated correctly. The unit must be replaced if stabilizer body has been damaged due to bolster or side frame lug interference to allow oil leakage at damaged area. Damaged stabilizer should be scrapped.

Stucki hydraulic stabilizers have a sight glass on one side of the reservoir to check for proper operating fluid level. On the HS-7 and HydraShox™ Platinum, the window is protected from dirt by a plastic cap, which must be removed to make the visual check. If the cap is missing, clean out any dirt on the surface of the glass. (A sliver of tie wood works well for this task.) Be sure the unit is sitting in its normal upright position when inspecting the sight glass.

A flashlight may be helpful in making the sight glass inspection. Figure 4.4 illustrates one of three conditions that may be encountered during inspection.



**A. WINDOW FULL**  
Unit OK



**B. PARTIALLY FULL**  
Replace at the  
next maintenance  
interval



**C. EMPTY**  
Replace ASAP

**FIG. 4.4 HYDRAULIC STABILIZER SIGHT GLASS WINDOW**

#### **Condition A.**

The oil level in the reservoir is full. The entire glass area will appear dark, and the unit should be left in service, regardless of any external sludge accumulation.

#### **Condition B.**

The oil level has dropped to the sight glass window, and only the upper portion of two shiny rings appears to be reflecting light. This indicates sufficient fluid remaining in the reservoir for adequate operation; however, it is the first warning the unit should be scheduled for replacement when the car is next shopped for routine maintenance. This is not an AAR or FRA defect as foreign cars are concerned. For system cars, however, it is advisable to replace when this condition is found.

#### **Condition C.**

The oil level has dropped below the sight glass area, and the two shiny rings are completely visible. The unit should be replaced as soon as possible. This condition constitutes a viable AAR or FRA defect.



Stabilizers equipped with a sight glass must be inspected according to above fluid level guidelines. **Only** stabilizers not equipped with a sight glass can be removed on the basis of wet fluid or build up > 3" from the unit. See AAR Field Manual Rule 50. HS-7, and HydraShox™ Platinum units removed due to low oil level should be returned to:

A. STUCKI COMPANY  
SALES@STUCKI.COM

Please call (412) 424-0560 in advance for a shipping address.

HydraShox™ Gold and HS-10s cannot be rebuilt. Once their reserve oil has been depleted, they should be discarded. Stabilizers should be replaced in kind.

## 5. GRATING

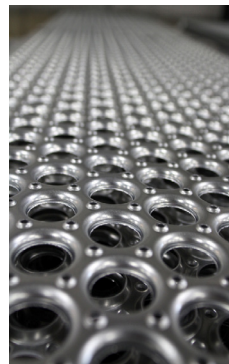


FIG. 5.1 STUCKI GRATING

Stucki's grip strut style grating offerings include running boards, ramp boards, platforms, end platforms, and brake steps for all car types, including direct replacements for most existing cars. Stucki's grating is made of 13 gauge G90 galvanized steel (G235 available upon request) and is AAR approved under S-226 and Rule 53 (Plate Type). Stucki also offers a full range of accessories, including mounting hardware, reinforcing clips, and hand grab application kits.

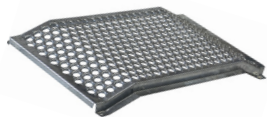


FIG. 5.2 RAMP BOARD



FIG. 5.3 BRAKE STEP



FIG. 5.4 END PLATFORM



FIG. 5.5 RUNNING BOARD



FIG. 5.6 CHANNEL BOARD

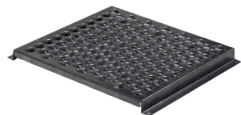


FIG. 5.7 END EXTENSION

TABLE 5.1

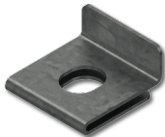
ITEM	DESCRIPTION
11315	1/2" Bolt Seat
10014	8-3/8" x 60-1/16" Crossover Board
09597	8" x 60" A-END Platform
9884	9-7/8" x 131-1/2" Running Board
10321	8" x 60" B-END Platform 16-17/32"
10680	9-7/8" x 70" Intermediate Board
10329	10" x 30" Brake Step
10242	1-1/2" x 1" x 7/16" Reinforcing Clip
10665	3" x 2" x 7/16" Reinforcing Clip
11224	9-5/8" x 74-3/8" Brake Step, B-END
11323	23-7/8" x 98" Running Board
9912	24" x 127-1/4" X 1-1/2" Running Board
11356	19-1/2" x 11-15/16" Platform Board



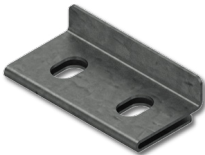
**FIG. 5.8 3/8" OR 1/2"  
BOLT SEAT**



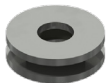
**FIG. 5.9 1/2" RIVET SEAT**



**FIG. 5.10 3/8" OR 1/2"  
REINFORCING CLIP**



**FIG. 5.11 3/8" OR 1/2"  
REINFORCING CLIP (2 HOLE)**



**FIG. 5.12 HAND GRAB MOUNTING  
WASHERS & BUSHING**

A full range of Stucki grating accessories are available.

## 6. BRAKE SYSTEMS



**FIG. 5.1 BRAKE BEAM**

TABLE 6.1

BRAKE BEAM	PART NUMBERS FOR COMP. SHOE BEAMS
# 18 Fixed RC	18-LSRC-CH (L or R)
#18 Fixed RCL	18-AFRC-CH (L or R)
#18 Reversible RC	18-LRRC-CH (L or R)
#24 Fixed RC	24-LSRC-CH (L or R)
#24 Fixed RCL	24-AFRC-CH (L or R)
# 24 Reversible RC	24-LRRC-CH (L or R)
	Specify (L) Left or (R) Right

All Stucki Brake Heads are replaceable.  
Quick Change Beams and Cast Iron Beams also available.

## INSPECTION

Replacement of brake beams can be considered for any of the inspection criteria below. Refer to AAR Field Manual of Interchange, Rule 6 for a detailed list of wear limits, gauging and causes for renewal.

1. Any brake beam tension or compression parts which are cracked, broken or worn more than half of the metal thickness
2. Damage or wear on brake beam head (heads alone can be replaced in lieu of entire beams)
3. Twisted beams (greater than 1 inch when comparing opposite heads against wheels)
4. Worn end extensions
5. Bent or twisted struts
6. Strut pin holes worn 3/16" or more
7. Slot lever worn 1/8" or more
8. Brake shoe wear is >1" from top to bottom
9. Worn brake beam liner more than half of its original thickness

## REVERSIBLE BRAKE BEAM PROCEDURE

Three steps for switching strut position RH or LH in the field (refer to Figure 5.2).

### FIRST

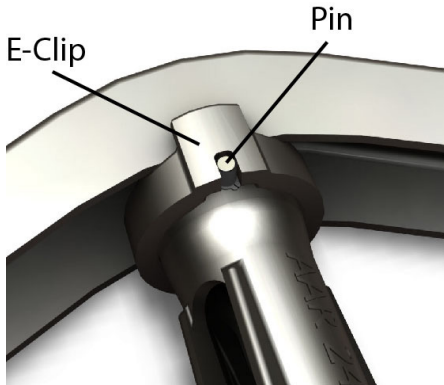
- Use screwdriver to pull retainer (e-clip) and pin (if tight, pin may be pushed from the opposite end, by the screwdriver).

### SECOND

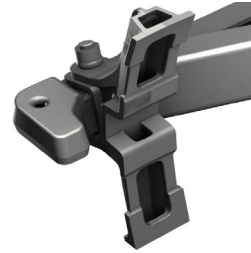
- Insert steel bar in strut lever slot.
- Tilt rotating strut 90 degrees, until the slots in end casting match slots in strut.

### THIRD

- Re-insert pin with groove end last.
- Reapply retainer by hand at pin groove (push it securely in place with screwdriver).



**FIG. 6.2 - STRUT AND PIN**



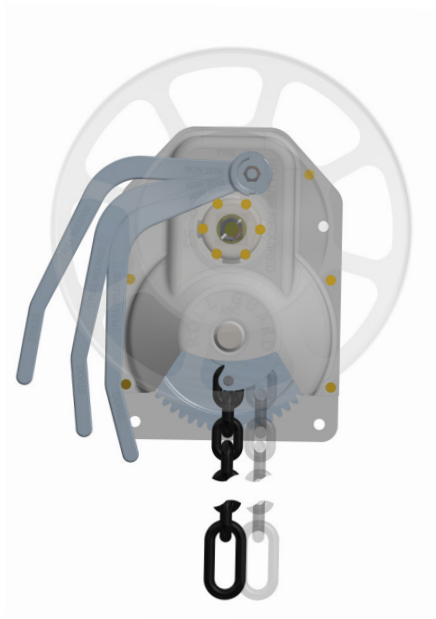
**FIG. 6.3  
BRAKE BEAM HEAD**



**FIG. 6.4  
REPLACEABLE HEAD**

### REPLACEABLE BRAKE HEAD PROCEDURE

1. Remove shoe.
2. Cut Huck™ with torch and remove damaged head from brake beam assembly.
3. Position replaceable head to align holes
4. Insert bolt through replaceable head and beam assembly combined. Apply washer assembly (large washer first, small washer next), and lock nut to threaded bolt. Tighten lock nut until orange silicon is visible (or 300 ft-lbs equivalent).
5. Install brake shoe and return to service.



**FIG. 6.5 ROLLGUARD™ HAND BRAKE  
GROUP N - LONG LEVER**

Short Lever also available.

## ROLLGUARD™ HAND BRAKE

### GROUP N FEATURES

- Long or short release levers
- Sealed, wider bearings for extended life and value
- Roller bearing at wheel/clutch axle for superior performance and smooth operation
- Lubrication free
- E-coated in rust-proof black oxide
- Certified under Hand Brake AAR Specification S-475
- Tight tolerances for reliable and consistent braking

A. Stucki Company offers RollGuard™ hand brake accessories as replacement parts or are available separately for new rail cars.



**FIG. 6.**  
**SHEAVE WHEEL**



**FIG. 6.7**  
**CLEVIS & PIN**



**FIG. 6.8**  
**HAND WHEEL**



**FIG. 6.9**  
**BELL CRANK**



**FIG. 6.10**  
**SHORT RELEASE**



**FIG. 6.11**  
**CHAIN JOINER**



**FIG. 6.12**  
**LONG RELEASE**

## STUCKI BRAKE SYSTEM ACCESSORIES

- Metallic Brake Beam Wear Guide
- Non-Metallic Brake Beam Wear Guide
- Brake Shoe Key
- Brake Rod Connector (1-1/8", 3/4" & 7/8")
- Truck Bottom Rods
- Brake Beam Centering Wear Liner

Stucki metallic, non-metallic, or Brake Beam Centering Wear Liners (Figures 6.13 and 6.14) are designed to work with any size or manufacture of brake beam under AAR S 367.

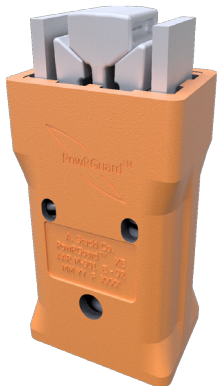


**FIG. 6.13**

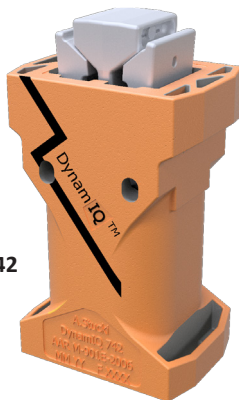


**FIG. 6.14**

## 7. DRAFT SYSTEMS



**FIG. 7.1 POWRGUARD™ XE DRAFT GEAR**



**FIG. 7.2 DYNAMIQ™ 742 DRAFT GEAR**

TABLE 7.1 DRAFT GEAR MODELS

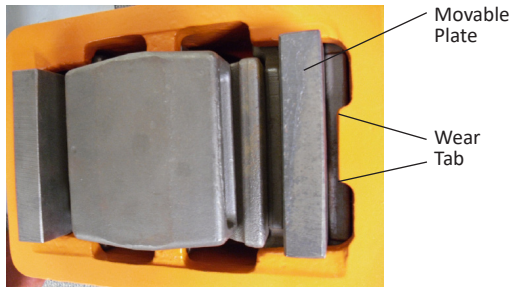
	POWRGUARD XE	POWRGUARD GXE	POWRGUARD GX	DYNAMIQ 742
Standard Pocket	Fits 24-5/8"	Fits 24-5/8"	Fits 24-5/8"	Fits 24-5/8"
AAR Approval	M-901E	M-901E	M-901G	M-901E
Official Rating Capacity	47,054 ft-lbs	45,643 ft-lbs	n/a	42,446 ft-lbs
Approximate Weight	367 lbs	367 lbs	367 lbs	312 lbs
Group Rule	Group J Rule 2.1	Group J Rule 2.1	Group J Rule 2.1	Group J Rule 2.1
Travel	3-1/4"	3-1/4"	3-1/4"	3-1/4"
Maximum Rating Impact Velocity	n/a	n/a	5.9 mph	7.8 mph
	Fits all standard yoke & car construction	Fits all standard yoke & car construction	Fits all standard yoke & car construction	Fits all standard yoke & car construction
	All steel	All steel with elastomer insert	All steel with elastomer insert	Elastomer gear with steel clutch

All models require AAR Y44 standard followers for E coupler application, or Y46 follower for F coupler application.



## POWRGUARD™ INSPECTION CRITERIA ALL CONDITIONS IN OR OUT OF CAR

Contact of the movable plate to the wear tab is cause for renewal. AAR Field Manual Rule 21 Section A also applies.



## 8. REPAIR AND RECONDITIONING

### AMERICAN INDUSTRIES

American Industries in Sharon, PA, Roanoke, VA, and Independence, MO, and the Midland Division in Jerseyville, IL provide railcar repair and reconditioning services to the railroad industry. This includes new, secondhand, gauged and reconditioned railroad parts. Facilities are certified under AAR M-212 and M-214, as well as QA certification M-1003.

Reconditioning services include:

- Wheel Sets
- Bolsters
- Sideframes
- Couplers
- Yokes
- Draft Gears
- Complete Truck Assemblies

Secondhand parts include:

- Air Brake Parts
- Yokes
- C10 Pins
- Couplers
- Follower Trucks
- Knuckles

#### WHEELS

American Industries and Seco Machine are AAR certified to provide freight car and locomotive wheel sets with new or reconditioned wheels, axles, and roller bearings.

American Industries provides interchange usable or second hand repairable axles and roller bearings at competitive prices.



## AMERICAN INDUSTRIES MIDWEST

### DISTRIBUTION AND RECONDITIONING SERVICES

American Industries Midwest business offers turnkey reconditioning services, and distributes many railcar components that A. Stucki Company manufactures. The business is a leading provider of railcar reconditioned components including:

- Bolsters
- Sideframes
- Duff-Norton Air Jacks
- Couplers
- Yoke Assemblies

All reconditioning and repair services are certified under AAR M-1003 and M-214, so the highest quality and reliability is guaranteed.

## DRAFT GEAR

Independent Draft Gear, a division of A. Stucki Company, reconditions, tests and pins the most commonly available draft gear per AAR M-901B Specifications. Refer to AAR Interchange Rule 21, Section B, Groups J & M for an overview of the draft gear models qualified. Locomotive gear/yoke assemblies are also reconditioned.

Other group type gears can be reconditioned and used for captive service.

## INSPECTION

Reconditioning of a draft gear can be considered when any of the defects listed in Section A of the AAR Field Manual Rule 21 are present. Refer to the manual for a detailed list of wear limits, gauging and cause for renewal.

Also, refer to manufacturer's specifications for In-Car and Out-of-Car inspection requirements for each individual model.

## FRICITION COMPONENT CLASSIFICATION

A gear must be reconditioned if any of its friction components are broken, damaged in any way, or missing.

Gears are classified as FC/C/D (Friction Component / Case / Damage) per the following criteria:

1. More than one broken or missing friction component
2. Center wedge is damaged
3. The gear is stuck in a compressed position

**CASE CLASSIFICATION**

As in the case of friction component damage, a draft gear must be rebuilt if the case has been subject to excessive wear or is damaged. Gears with cases that meet the following are also considered FC/C/D:

1. Wall thickness - visibly worn case wall
2. Torch cut - 1 inch or more

**SCRAP CLASSIFICATION**

Gears with bulges, split cases or cracks in excess of 2 inches cannot be repaired and are classified as scrap. Also, gears not listed on the IDG list of acceptable gears are either not reconditionable or are obsolete and therefore classified as scrap. Refer to AAR Rule 21.

Gears which meet the criteria for reconditioning should be shipped to:

**INDEPENDENT DRAFT GEAR  
1000 MARTIN LUTHER KING JR. BLVD.  
FARRELL, PA 16121  
TEL: (724) 981-2251  
FAX: (724) 981-2256**

## 9. BEARING ADAPTERS

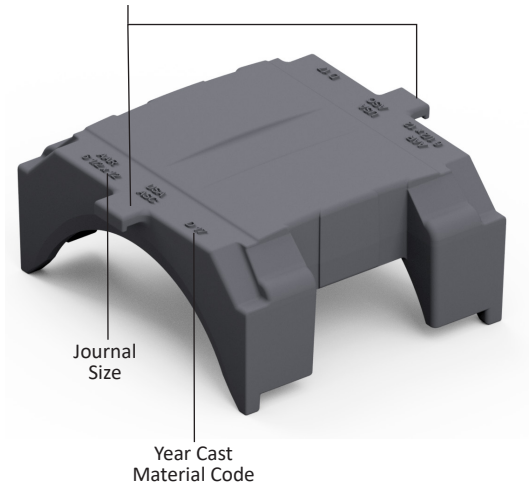
6-1/2"x12" Journal Ductile  
 6-1/2"x12" Journal Ductile, Crown  
 Hardened

Stucki roller bearings adapters can be applied to any 100 ton truck applications or to any 6-1/2x12 roller bearing journal size. They are available with hardened crowns (HC), or with hardened crowns and thrust shoulders (HCT). These are indicated on the outer edge of the bearing adapter.

Wear limits for bearing adapters are indicated by the worn crown surface to the level of the relief at the center and ends of the adapter. Adapters should be replaced in kind when any crowned area is worn to the point where the relief area is contacted by the truck frame. See AAR Rule 37 for additional information.

**FIG. 9.1 STUCKI 6-1/2 x 12"  
 ROLLER BEARING ADAPTER**

Hardened Surface Code  
 C - Crown  
 T - Thrust Shoulder  
 CT - Crown & Thrust Shoulder



## 10. PINS

A variety of truck center pins, with sizes and tapers, can be found on Table 10.1. Draft system yoke and coupler pins are also offered for a variety of applications.



TABLE 10.1 PINS

	PIN TYPE	DIMENSIONS	WEIGHT	TAPER
<b>A</b>	C10 Knuckle	13 <sup>3</sup> / <sub>8</sub> " x 1 <sup>5</sup> / <sub>8</sub> "	8.3 lbs	---
<b>B</b>	38080 Yoke & Coupler	9 <sup>1</sup> / <sub>16</sub> " x 3 <sup>1</sup> / <sub>2</sub> "	26.5 lbs	---
<b>C</b>	Y47 Yoke & Coupler	11 <sup>15</sup> / <sub>16</sub> " x 3 <sup>1</sup> / <sub>2</sub> "	33.3 lbs	---
<b>D</b>	50631 Yoke & Coupler	10 <sup>1</sup> / <sub>2</sub> " x 3 <sup>3</sup> / <sub>4</sub> "	32 lbs	---
<b>E</b>	Center	1 <sup>3</sup> / <sub>4</sub> " x 15"	9.8 lbs / 9.65 lbs	Single/Double
	Center	2" x 15"	13.3 lbs / 13.3 lbs	Single/Double
	Center	2" x 18"	16 lbs / 16 lbs	Single/Double
<b>F</b>	Locking Center Pin	16 <sup>3</sup> / <sub>8</sub> " L x 1 <sup>1</sup> / <sub>4</sub> "	12.04 lbs	Double
<b>G</b>	Locking Center Pin Retainer	---	---	---
<b>H</b>	5103 Locomotive Pivot Pin	13" x 3 <sup>1</sup> / <sub>2</sub> "	36.26 lbs	---
<b>I</b>	7291 Locomotive Draft Pin	12 <sup>1</sup> / <sub>2</sub> " x 2 <sup>1</sup> / <sub>4</sub> "	13.7 lbs	---
<b>J</b>	Brake Pins	*	---	---

\* Special sizes are available. We carry a wide variety of all the common brake pins. Contact us for details.

A dramatic sunset over a railway track. The sky is filled with dark, heavy clouds on the left, transitioning to bright orange and yellow light from the setting sun on the right. Sunbeams break through the clouds. The railway tracks run from the bottom left towards the horizon on the right. The ground is covered in gravel and some green grass. There are some trees in the background.

Additional product guides  
are available for sale  
at [sales@stucki.com](mailto:sales@stucki.com)  
or call for assistance  
(412) 424-0560

**A. STUCKI**  
.....COMPANY

# **A. STUCKI**

.....C O M P A N Y

## **American Industries**

Sharon, PA  
724-981-4100

Independence, MO  
816-836-1901

Jerseyville, IL  
618-498-4442

Roanoke, VA  
540-491-0040

Cleveland, TX  
281-622-4194

## **Alco Spring Industries**

Chicago Heights, IL  
708-755-0438

## **American Turbocharger Technologies**

Newport News, VA  
757-244-1456

## **Magnus**

Fremont, NE  
402-721-9540

## **Independent Draft Gear**

Farrell, PA  
724-981-2251

## **Stucki Roller Bearing**

Elizabethtown, KY  
270-735-1912

## **A. Stucki Co. Warehouse**

% Seco Machine  
North Canton, OH  
330-499-2150

**Stucki de Mexico, S. de R.L. de C.V. +52 (81) 8007 7300**  
**A. Stucki do Brasil Ltda +55 (11) 3842 4630**